



100 Series

Semi-Automatic Case Erectors



101/2/3

Each machine can be used either on its own or close-coupled to a case sealer to provide a simple and effective system and is suitable for a range of case sizes; 101 allows for a small range, 102 medium range and 103 a large range for case forming, loading and sealing.



Compact

Our machines have a compact footprint and will not take up a great deal of space in your production area. They are fully portable with adjustable legs to enable the tilt angle to be customised.



121/2/3

These machines can be set to an angled position, which is ideal for products that are unstable such as bags or bottles. The machine incorporates a section of horizontal belt drive so the case is horizontal at entry to the sealer.



Simple to operate

With no need to make any adjustments for size change, they can be set up and running in seconds.



Efficient

Our case formers reduce the time and effort taken to manually erect and load a case and you can also save space and time by eliminating the need to hold pre-erected cases near the packing area.



Low cost of ownership

All Endoline's machines are designed for maximum efficiency and productivity thereby reducing the cost of ownership to a minimum. Our case formers come at a low capital cost and immediate savings can be seen through reduced labour costs and increased packing speeds.





100 Series

Semi-Automatic
Case Erectors

Options include:

- Locating spacers to secure to a case sealer
- Locking castors

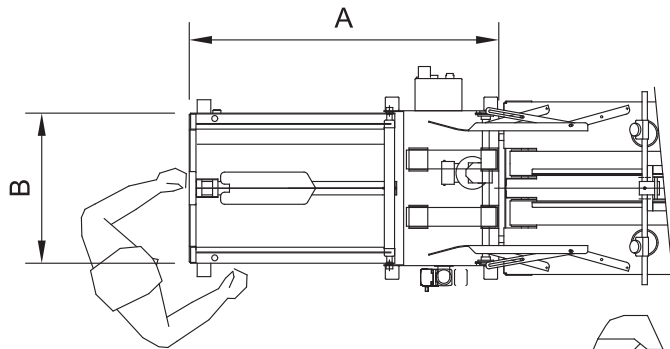

	A	B	C
101	695	482	615-900
102	790	662	625-925
103	900	762	605-905

	A	B	C
121	1155	382	700-980
122	1155	560	700-980
123	1155	660	700-980

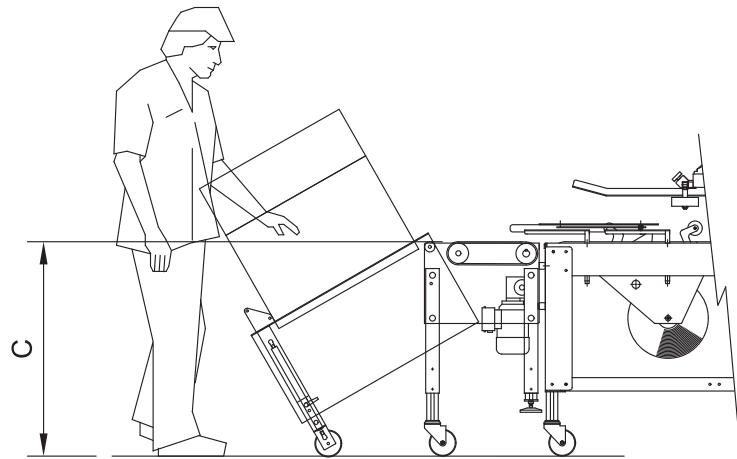

Case Dimensions (mm).

	Length min/max	Width min/max
101	200/400	120/250
102	200/500	150/400
103	200/600	150/500
121	200/400	120/250
122	200/600	150/400
123	200/600	150/500

Pneumatics

- 5.5 bar supply pressure

Machine Finish

- Mild steel powder coated white
- (RAL 9010) or stainless steel

© Endline reserves the right to change specifications without prior notice.

Endline Machinery Limited

Stratton Business Park, London Road Biggleswade, Bedfordshire SG18 8QB United Kingdom
Telephone: +44 (0) 1767 316422 Facsimile: +44 (0) 1767 318033 E-mail: sales@endline-automation.com

