



2218

Fully Automatic Case Erector



Dual Opposing Vacuum Case Opening

This unique design feature ensures that each case is opened positively from both sides. It ensures the efficient and reliable opening of cases, and overcomes problems that can be associated with stiff board and glue migration from the manufacturer's joint.



Compact

With a surprisingly compact footprint these machines will fit in to areas with restricted floor space or areas not normally suited to the installation of large or bulky machinery.



Easy to Use

The 2218 series is designed with clear access, simple controls and quick to adjust to size changes. The machines are operator friendly and allow for quick and easy size change, cleaning and maintenance to ensure minimal machine down time.



Low Cost of Ownership

The Endline 2218 Fully Automatic Case Erector is designed to give you the best possible value for your investment through maximum productivity with minimal stoppage time for problem-solving or case size changes.



Clear Access

Simple mechanical operation and clear access for easy size change, cleaning and maintenance.



Robust Construction

High quality components, housed in a robust, computer designed chassis allow for minimal servicing. Designed for the rigours of typical end-of-line packaging environments.





2218

Fully Automatic
Case Erector

Options include:

- Extended Hopper Magazine
- Low hopper sensing
- Low tape and no tape sensing
- Visual/audible failure alarm
- High speed

2218 dimensions shown

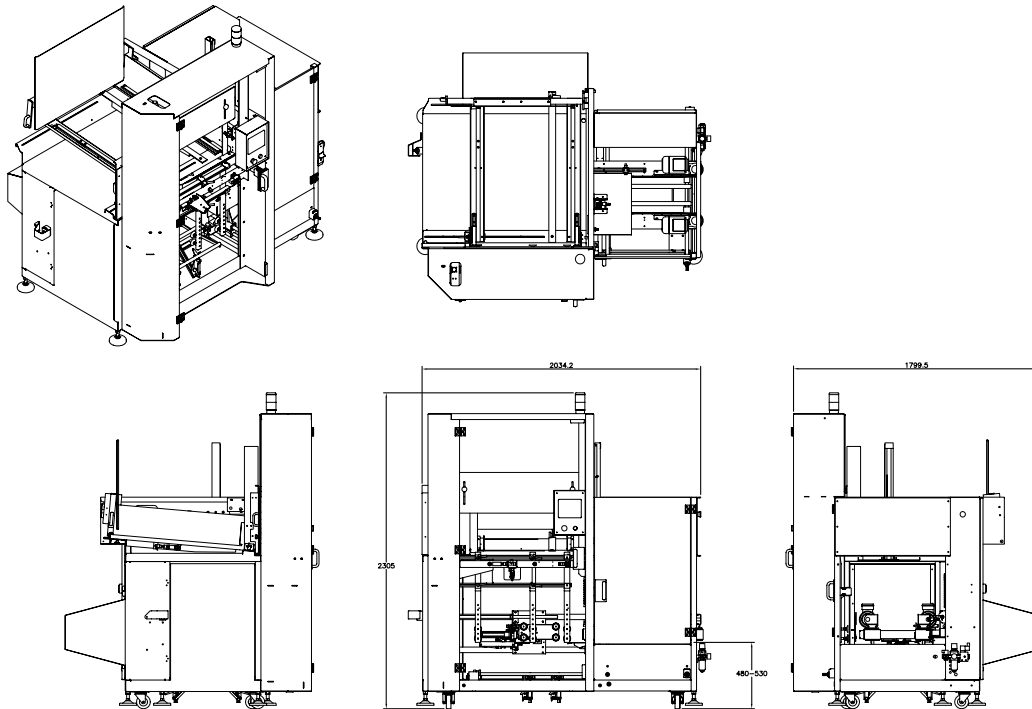

Case Dimensions (mm).

	Length	Width	Height (Open)
2218 Minimum	200	150	175
Maximum	650	400	600

Note:

- The 2218 case erector seals cases with self adhesive tape.
- Case speeds subject to case size.
- Machine can be modified for cases outside case size range. Please contact Endoline to advise.

Electrical

- Type 221 Three phase:
380 - 415V, 50Hz, 0.5kW

Machine Finish

- Mild steel, powder coated white (RAL 9010) or stainless steel

Speed

- Standard in feed up to 12 cases per minute
- Optional up to 14 cases per minute

Pneumatics

- 80psi (5.5 bar)

Tape Size

- Standard: up to 50mm wide
- Optional: up to 75mm wide

© Endoline reserves the right to change specifications without prior notice.

Endoline Machinery Limited

Stratton Business Park, London Road Biggleswade, Bedfordshire SG18 8QB United Kingdom
Telephone: +44 (0) 1767 316422 Facsimile: +44 (0) 1767 318033 E-mail: sales@endoline-automation.com

