



# 602-607

## Fully Automatic Pre-Set Case Taper



### Interchangeable Tapeheads

The 602/607 uses any machine tape up to 50mm wide, 1000m long and features instantly removable, interchangeable tapeheads, easily threaded, with integral knife guards.



### Robust Construction

High quality components housed in a robust chassis ensure minimal servicing and enable 24 hour operation. All our case tapers are designed for the rigours of typical end-of-line packaging environments.



### Floating Bridge

This unique design feature allows the machine to accept swollen or out-of-specification cases while providing consistent and accurate sealing.



### Unique spring-loaded side belt driven system

This ensures that there is no slippage or bunching of cases often found with other systems.



### Ease of Operation

The 602/607 has simple mechanical operation and clear access for easy cleaning and maintenance. It is designed to be operator friendly with simple controls and is quick and easy to adjust to case size changes.



### Low Cost of Ownership

The Endline 602/607 are designed to give you the best possible value for your investment through maximum productivity with minimal stoppage time for problem-solving or case size changes.



# Pre-set Case Sealers



## 602/607

Fully Automatic  
Pre-Set Case Taper

### Options include:

- No tape and low tape sensing
- Visual/audible alarm
- Discharge blocked sensor
- Fully interlocked guards
- Tapehead/folder head lift cylinder unit
- Case indexing unit

### 602 dimensions shown

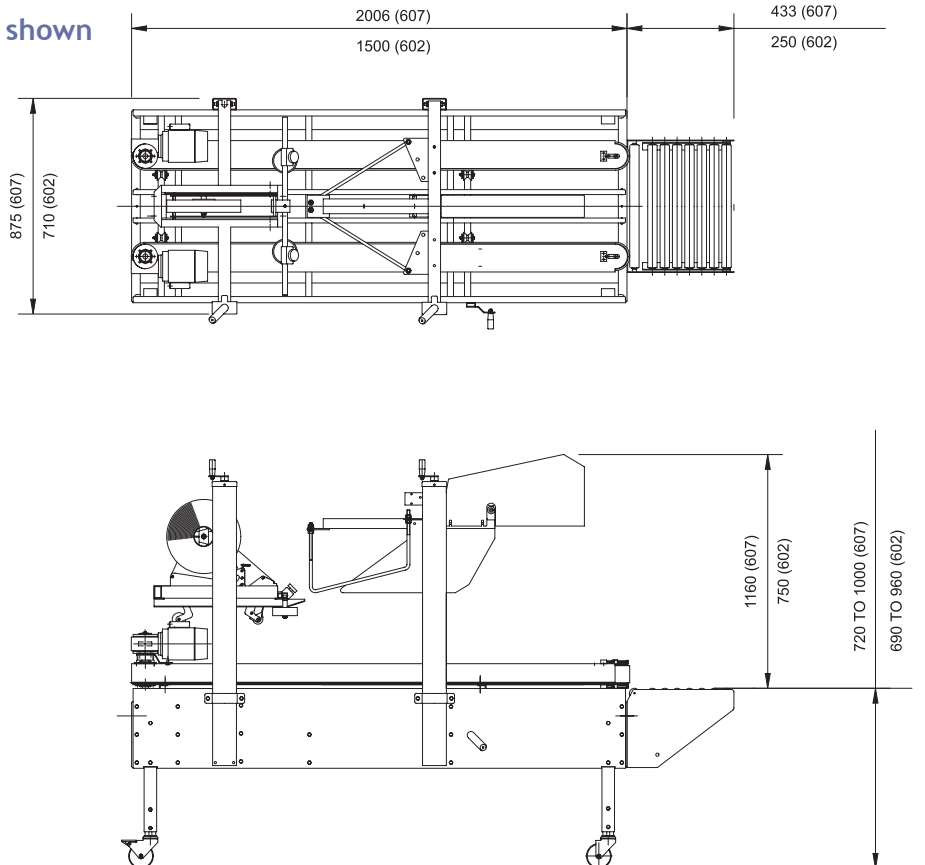

### Case Dimensions (mm).

	Length	Width	Height
Type 602	150-400	100-340	110-370
Type 607	150-600	110-500	110-600

### Note:

- 602 case sealer suitable for small and narrow cases.
- 607 case sealer suitable for larger heavier cases.
- Speeds up to 30 cases per minute subject to case size.
- Machine can be modified for cases outside case size range. Please contact Endoline to advise.

### Electrical

- Type 602
- Three phase: 415V, 50Hz
- Type 607
- Three phase: 415V, 50Hz

### Machine Finish

- Mild steel, powder coated white
- (RAL 9010) or stainless steel

### Tape Supply

- Standard: up to 50mm wide
- Optional: up to 75mm wide

### Pneumatics

- 80psi (5.5 bar)

© Endoline reserves the right to change specifications without prior notice.

### Endoline Machinery Limited

Stratton Business Park, London Road Biggleswade, Bedfordshire SG18 8QB United Kingdom  
Telephone: +44 (0) 1767 316422 Facsimile: +44 (0) 1767 318033 E-mail: sales@endoline-automation.com

www.endoline-automation.com

