









611

Pre-set Fully Automatic Case Taper

-  **Interchangeable Tapeheads**
The 611 uses any machine tape up to 50mm wide, 1000m long and features instantly removable, interchangeable tapeheads, easily threaded, with integral knife guards.
-  **Low Cost of Ownership**
The Endline 611 is designed to give you the best possible value for your investment through maximum productivity with minimal stoppage time for problem-solving or case size changes.
-  **Robust Construction**
High quality components housed in a robust chassis ensure minimal servicing and enable 24 hour operation. All our case tapers are designed for the rigours of typical end-of-line packaging environments.
-  **Ease of Operation**
The 611 has simple mechanical operation and clear access for easy cleaning and maintenance. It is designed to be operator friendly with simple controls and is quick and easy to adjust to case size changes.
-  **Unique spring-loaded side belt driven system**
This ensures that there is no slippage or bunching of cases often found with other systems. This drive mechanism is suitable for both light weight small cases and larger heavier cases.
-  **Extended Warranty**
Two year fully comprehensive warranty for peace of mind and reduced cost of ownership.





611

Pre-set
Fully Automatic
Case Taper

Options include:

- No tape and low tape sensing
- Visual/audible alarm
- Discharge blocked sensor
- Fully interlocked guards
- Case indexing unit

611 dimensions shown

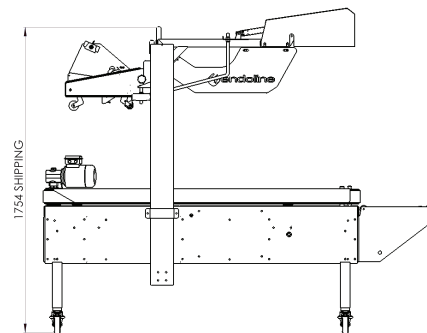
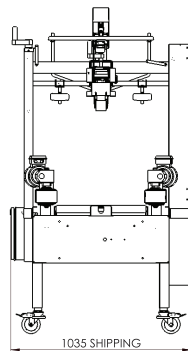
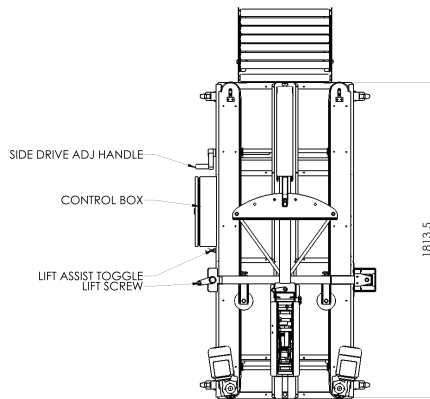

MACHINE SHIPPING WEIGHT IS APPROXIMATELY 215KG



Case Dimensions (mm).

	Length	Width	Height
Minimum	150	90	110
Maximum	600	500	630

Note:

- Machine can be modified for cases outside case size range. Please contact Endoline to advise.
- Machine is fully CE certified.
- Speeds up to 30 cases per minute subject to case size.

Electrical Supply

- Three phase:
- 380/415V, 50Hz
- 0.36kW
- 6A /phase amps

Tape Supply

- Standard: up to 50mm wide
- Optional: up to 75mm wide

Machine Finish

- Mild steel, powder coated white
- (RAL 9010) or stainless steel

Pneumatics

- 150psi Max
- 80psi (5.5 bar)
- Lt. Per Cycle: 0.4
- Connection size: 12mm

© Endoline reserves the right to change specifications without prior notice.

Endoline Machinery Limited

Stratton Business Park, London Road Biggleswade, Bedfordshire SG18 8QB United Kingdom
Telephone: +44 (0) 1767 316422 Facsimile: +44 (0) 1767 318033 E-mail: sales@endoline-automation.com

