



621/625

Pre-Set Semi Automatic Case Sealer



Efficient

The 625 has a unique 'floating bridge' feature that copes with swollen or out of specification cases. This means it is less critical to obtain exact height adjustments, therefore considerably reducing changeover time.



Interchangeable Tapeheads

The 625 has two identical, easy to thread interchangeable tapeheads, which means that tape reloading time is reduced.



Flexible

The 621 can be used for bottom tape only and the 625 can be used as top and bottom tape. Both can be integrated with a 100 series case former to reduce packing time further.



Clear Access

The machine design provides quick and easy access to the bottom tape head and the computer designed chassis reduces dirt traps for ease of cleaning and maintenance.



Ease of Operation

The machine automatically re-sets after tape loading and the simple construction allows for lower maintenance through fewer moving parts.



Compact

Our machines have a compact footprint and will not take up a great deal of space in your production area. They are fully portable with adjustable legs with height scales for easy installation.



Pre-set Case Sealers



621/625

Pre-Set
Semi Automatic
Case Sealer

Options include:

- Low tape sensing
- Low tape and no tape sensing
- Visual/audible alarm
- Discharge blocked sensing
- Packing tables
- Infeed/discharge conveyors
- Coding systems

625 dimensions shown

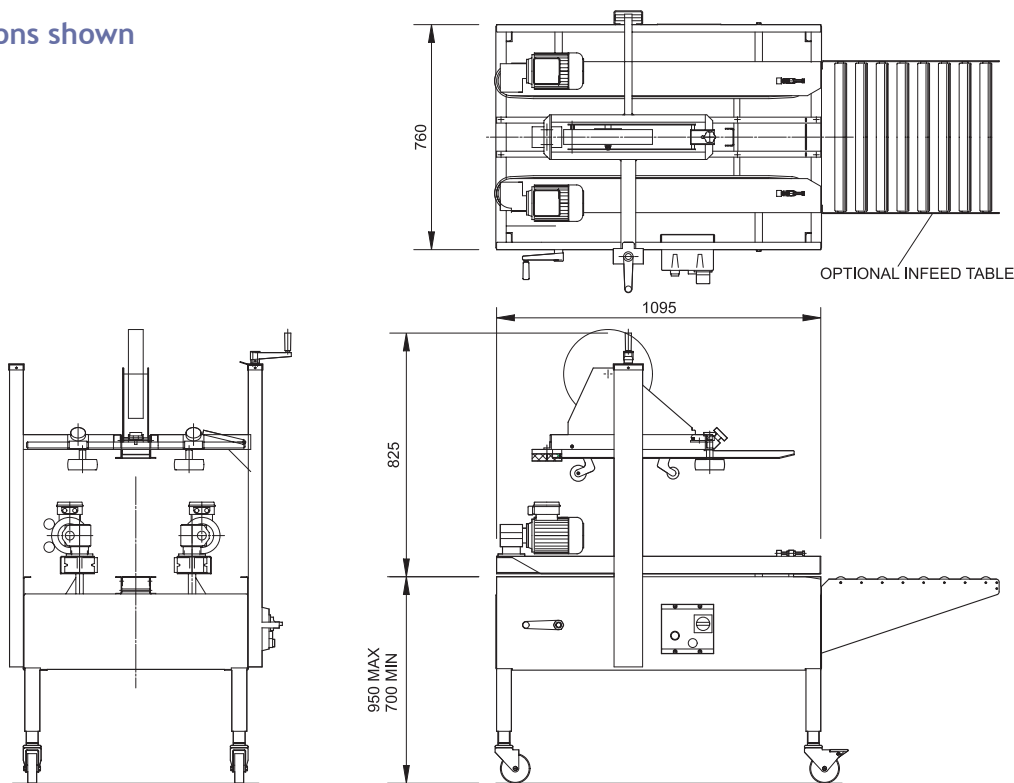

Case Dimensions (mm).

	Length	Width	Height (high position)
Type 621	110-inf	100-500	60-inf
Type 625	110-inf	100-500	110-510

Note:

- Machine can be modified for cases outside case size range. Please contact Endline to advise.

Electrical

- Single Phase: 240V, 50Hz, 0.36kW
- Three Phase: 415V, 50Hz, 0.36kW

Tape Size

- Standard: up to 50mm wide
- Optional: up to 75mm wide

Machine Finish

- Mild steel powder coated white (RAL 9010) or stainless steel

© Endline reserves the right to change specifications without prior notice.

Endline Machinery Limited

Stratton Business Park, London Road Biggleswade, Bedfordshire SG18 8QB United Kingdom
Telephone: +44 (0) 1767 316422 Facsimile: +44 (0) 1767 318033 E-mail: sales@endline-automation.com

www.endline-automation.com

