



# 706

## Semi-Automatic Pre-Set Case Taper



### Floating Bridge

This unique design feature allows the machine to accept swollen or out-of-specification cases while providing consistent and accurate sealing.



### Ease of Operation

The 706 is easy to install with height adjustment and castors. It has simple mechanical operation and clear access for easy cleaning and maintenance.



### Twin Column Construction

Our unique twin column design provides added stability for the taping bridge to ensure the machine runs smoothly at all times with minimal interruption. It provides the support necessary for the floating bridge feature.



### Robust Construction

High quality components housed in a robust chassis ensure minimal servicing and enable 24 hour operation. All our case tapers are designed for the rigours of typical end-of-line packaging environments.



### Interchangeable Tape Heads

The 706 uses any machine tape up to 50mm wide, 1000m long and features instantly removable, interchangeable tapeheads, easily threaded, with integral knife guards.



### Extended Warranty

Two year fully comprehensive warranty for peace of mind and reduced cost of ownership.



# Pre-set Case Sealers



## 706

Semi-Automatic  
Pre-Set Case Taper

### Options include:

- Low tape sensing
- Low tape and no tape sensing
- Visual/audible alarm
- Discharge blocked sensing
- Packing tables
- Infeed/discharge conveyors
- Coding systems

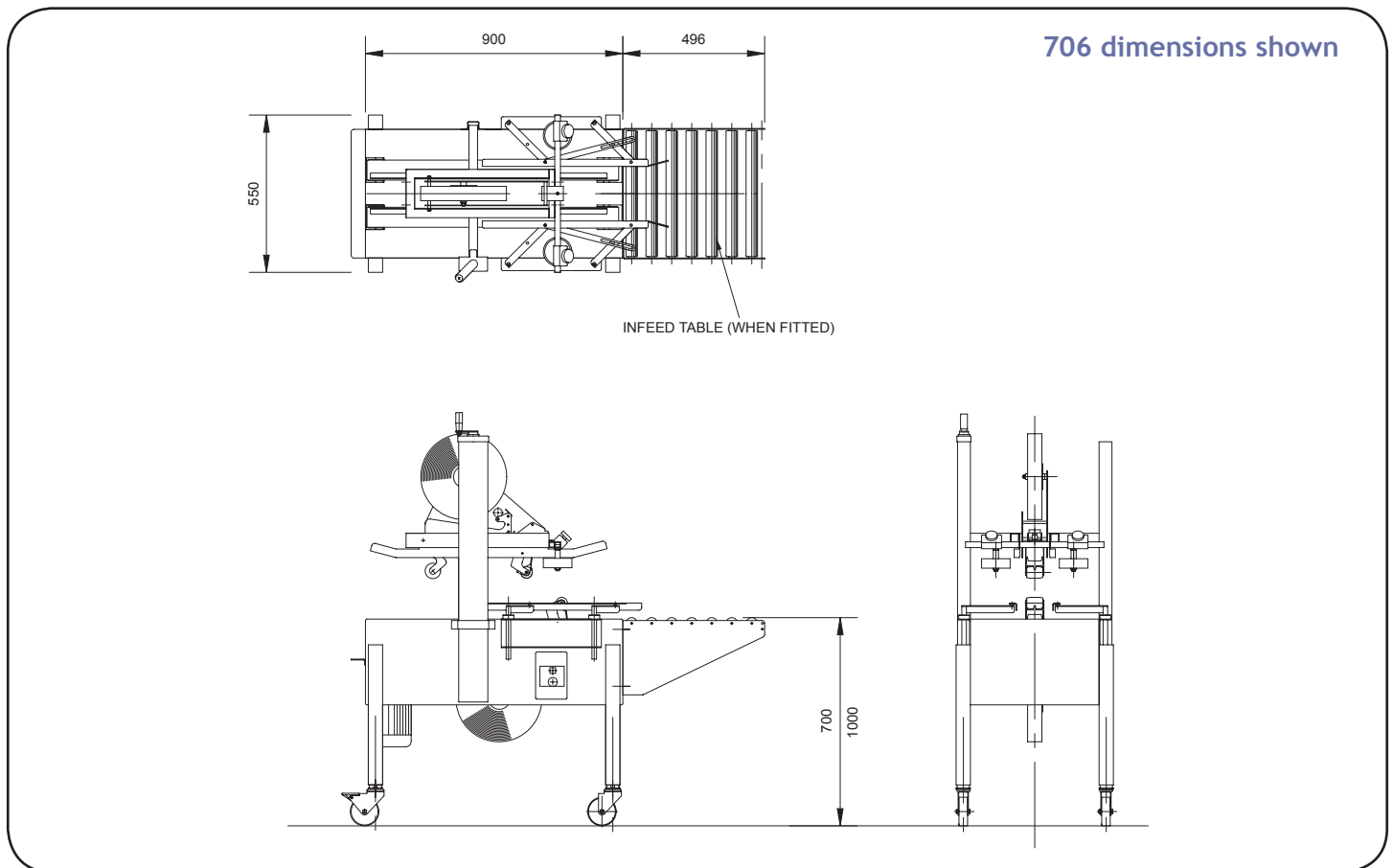

### Case Dimensions (mm).

	Length	Width	Height
Minimum	110	114	50
Maximum	inf	500	510

### Note:

- Machine can be modified for cases outside case size range. Please contact Endline to advise.

### Electrical Supply

- Single phase: 240V, 50Hz, 0.37kW
- Three phase: 415V, 50Hz, 0.37kW

### Machine Finish

- Mild steel, powder coated white (RAL9010) or stainless steel

### Tape Size

- Standard: up to 50mm wide
- Optional: up to 75mm wide

© Endline reserves the right to change specifications without prior notice.

### Endline Machinery Limited

Stratton Business Park, London Road Biggleswade, Bedfordshire SG18 8QB United Kingdom  
Telephone: +44 (0) 1767 316422 Facsimile: +44 (0) 1767 318033 E-mail: sales@endline-automation.com

www.endline-automation.com

