



710

Semi-Automatic Pre-set Case Sealer



Floating Bridge

This unique design feature allows the machine to accept swollen or out-of-specification cases while providing consistent and accurate sealing.



Twin Column Construction

Our unique twin column design provides added stability for the taping bridge to ensure the machine runs smoothly at all times with minimal interruption. It provides the support necessary for the floating bridge feature.



Interchangeable Tape Heads

The 710 uses any machine tape up to 50mm wide, 1000m long and features instantly removable, interchangeable tapeheads, easily threaded, with integral knife guards.



Ease Of Operation

The 710 is very simple to operate with clear access for side coding, easy cleaning and maintenance. It also offers rapid adjustment for size changes therefore minimising down time.



Robust Construction

High quality components housed in a robust chassis ensure minimal servicing and enable 24 hour operation. All our case tapers are designed for the rigours of typical end-of-line packaging environments.



Extended Warranty

Two year fully comprehensive warranty for peace of mind and reduced cost of ownership.





710

Semi-Automatic
Pre-set Case Sealer

Options include:

- Low tape and no tape sensing
- Packing tables
- Infeed/discharge conveyors
- Coding systems

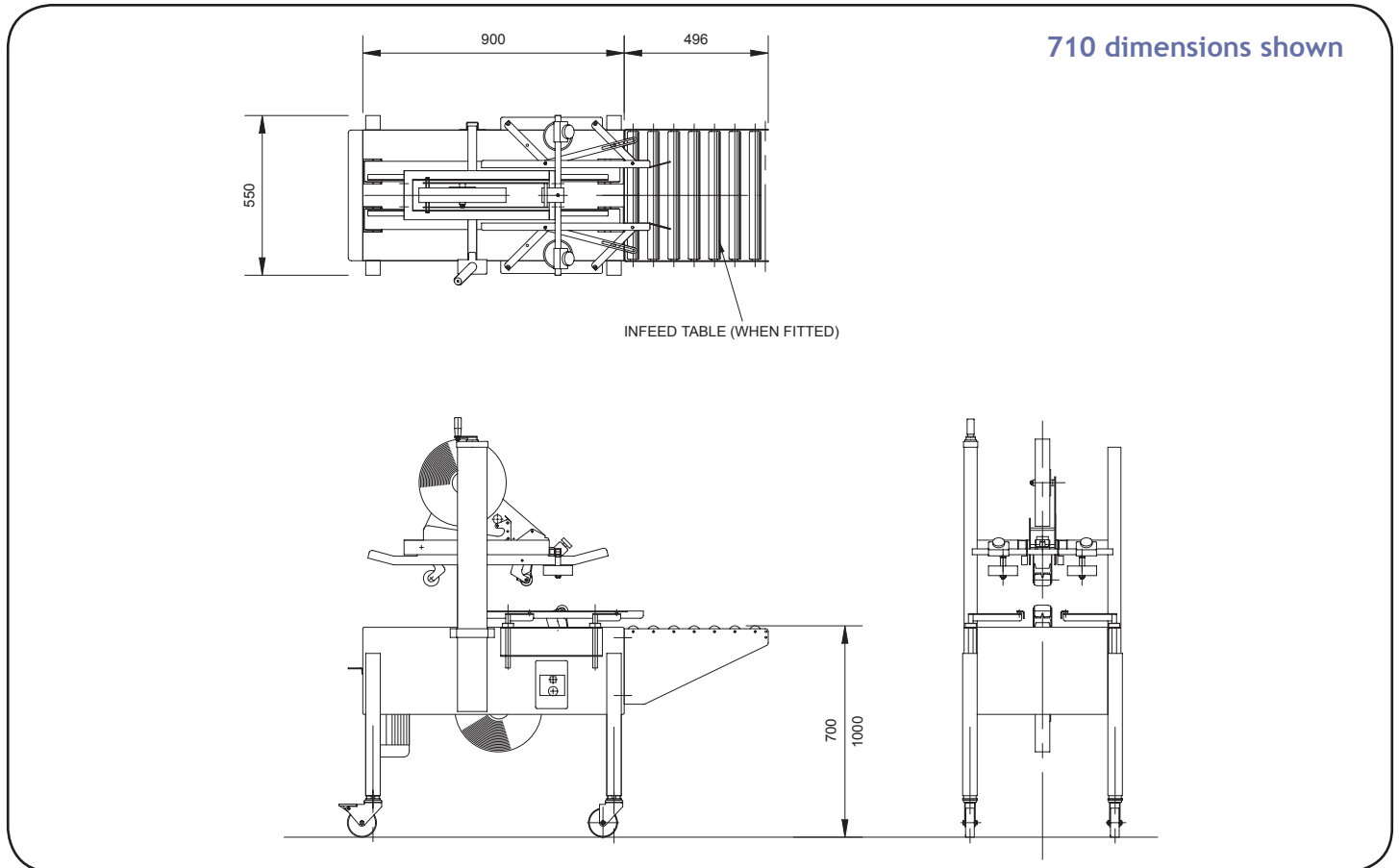

710 dimensions shown



Case Dimensions (mm).

	Length	Width	Height
Minimum	110	114	110
Maximum	inf	385	500

Note:

- Machine can be modified for cases outside case size range. Please contact Endline to advise.

Electrical Supply

- Single phase: 240V, 50Hz, 0.37kW
- Three phase: 415V, 50Hz, 0.37kW

Tape Size

- Standard: up to 50mm wide
- Optional up to 75mm wide

Machine Finish

- Mild steel, powder coated white (RAL9010) or stainless steel

© Endline reserves the right to change specifications without prior notice.

Endline Machinery Limited

Stratton Business Park, London Road Biggleswade, Bedfordshire SG18 8QB United Kingdom
Telephone: +44 (0) 1767 316422 Facsimile: +44 (0) 1767 318033 E-mail: sales@endline-automation.com

